

PASS-THRU REFRIGERATOR

Model: 1RENPTHD

Natural Refrigerant R-290 Model

1-Section Extra-Wide Pass-Thru Refrigerator with Half Doors



ENERGY STAR® Qualified Commercial Refrigerator

1RENPTHD - Stainless steel front, aluminum end panels and interior

1RENSAPTHD - Stainless steel exterior, aluminum interior

1RENSSPTHD - Stainless steel exterior and interior



Options and Accessories

(upcharge and lead times may apply)

Additional epoxy coated steel shelves	Hinged glass doors (consult factory)
Chrome or stainless steel shelves	Special electrical req. (consult factory)
Rehinging of doors (consult factory)	Correctional Facility Options
Pan slide assemblies	<ul style="list-style-type: none"> • One way security screws
Wine rack	<ul style="list-style-type: none"> • Locking hasp (lock not included)
Adjustable legs	<ul style="list-style-type: none"> • Stainless steel mesh cover
Custom laminates	<ul style="list-style-type: none"> • Coverless hinges
Full door	

Consult factory for other model configurations, options and accessories.

Continental
Refrigerator

Toll-Free: 800-523-7138
Phone: 215-244-1400
Fax: 215-244-9579

539 Dunksferry Road
Bensalem, PA 19020
www.continentalrefrigerator.com

Project Name:

Model Specified:

Location:

Item No:

Quantity:

AIA #:

SIS #:

Standard Model Features

REFRIGERATION SYSTEM

Self contained, performance rated "plug" refrigeration system

Natural, environmentally safe, high efficiency R-290 refrigerant¹

Refrigeration system is readily accessible on top of cabinet, separate from the "food zone"

Automatic, hot gas condensate evaporator

Expansion valve system

CABINET ARCHITECTURE

3" non-CFC polyurethane foam insulation

Smooth, polished chrome workflow door handles

Cam action, lift off hinges

Self-closing doors

Magnetic snap in Santoprene™ door gaskets

Cylinder lock in each door

Heavy duty, epoxy coated steel shelves

Heavy duty pilaster strips

5" casters

MODEL FEATURES

LED interior lighting

Electronic controller with digital display & hi-low alarm

Top and side air distribution ducts

Off-cycle defrost

Cabinet upper side panels and refrigeration "plug" system can be removed and reinstalled at job site

¹ R-290 refrigerant meets all federal and state regulatory requirements.

APPROVAL:

Model Specifications

DIMENSIONAL DATA

Net Capacity (cubic feet)	22 (623 cu l)
Width, Overall (inches)	28 1/2 (724 mm)
Depth, Overall (inches) (including handles)	38 3/4 (984 mm)
Depth (inches) (less doors)	32 (813 mm)
Depth (inches) (doors open 90°)	79 (2007 mm)
Clear Door Width (inches)	21 7/8 (556 mm)
Clear Half Door Height (inches)	27 1/2 (699 mm)
Height, Overall (inches) (including 5" casters)	82 1/4 (2089 mm)
Number of Doors	4
Number of Shelves	3
Shelf Area (square feet)	20.4 (1.9 sq m)
Tray Slide Capacity (per half section)	11

REFRIGERANT DATA

Condensing Unit Size (H.P.)	1/4
Capacity (BTU per hour)*	1940

ELECTRICAL DATA

Voltage (International)	115/60/1 (220/50/1)
Feed Wires (including ground)	3
Total Amps (International)	5.5 (3.9)
10 ft. Cord/Plug [attached] (International)	Yes (No)

SHIPPING DATA

Height - Crated (inches)	85 1/2 (2172 mm)
Width - Crated (inches)	31 5/8 (803 mm)
Depth - Crated (inches)	42 (1067 mm)
Volume - Crated (cubic feet)	65 (1841 cu l)
Weight Std - Crated (pounds)	360 (163 kg)
Weight SS - Crated (pounds)	380 (172 kg)

* Rating @ +25°F evaporator, 90°F ambient
 Figures in parentheses reflect metric equivalents rounded to the nearest whole unit.



Equipped with one NEMA-5-15P Plug
 (varies by country)

Model Plan Views

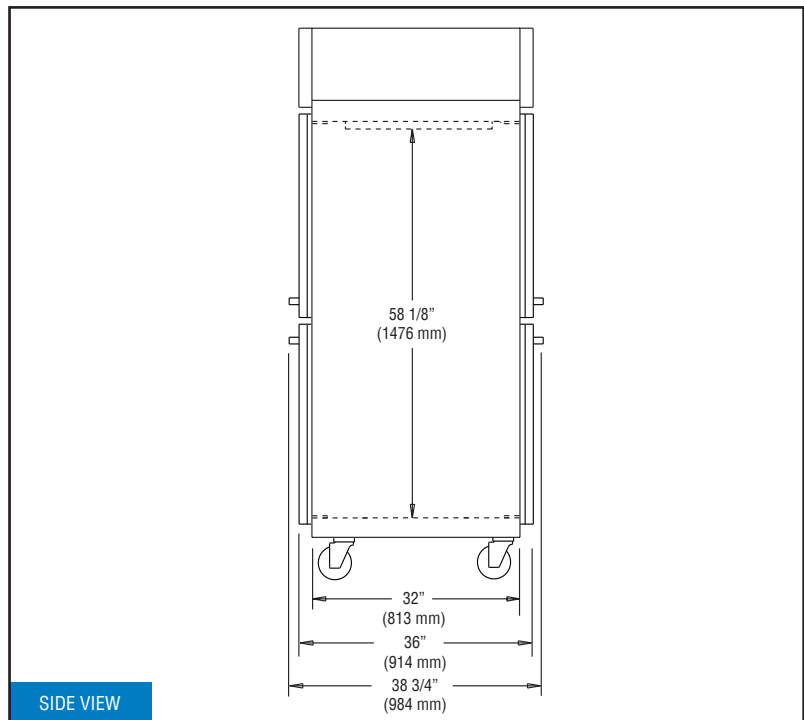
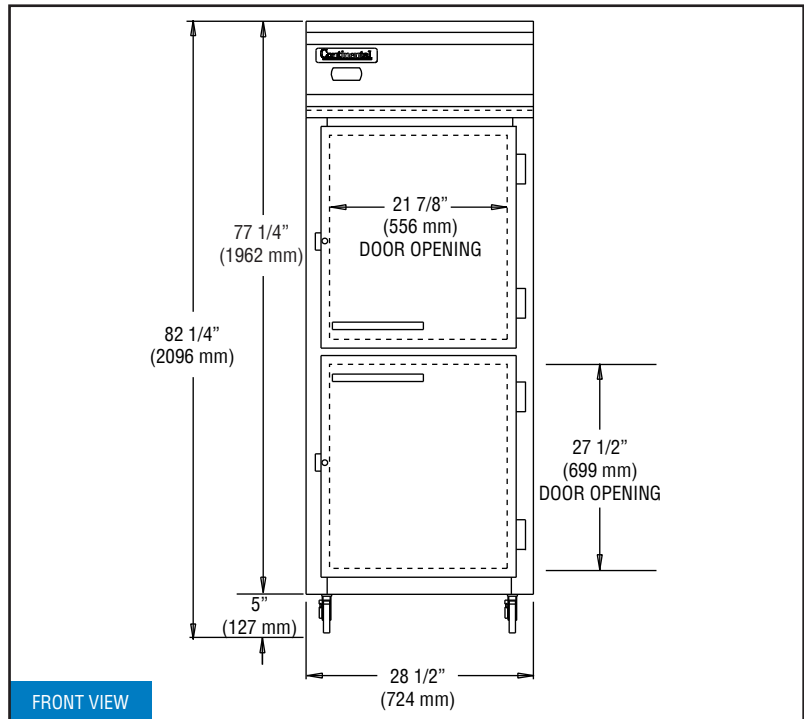

IMPORTANT NOTE: If the cabinet is located under a low ceiling, a minimum clearance of 12" is required on top and 3" on sides.



Toll-Free: 800-523-7138
 Phone: 215-244-1400
 Fax: 215-244-9579

539 Dunksferry Road
 Bensalem, PA 19020
www.continentalrefrigerator.com

Due to our continued efforts in developing innovative products, specifications subject to change without notice.

